

Oak Relay

4 Channel Relay Output Card

Datasheet

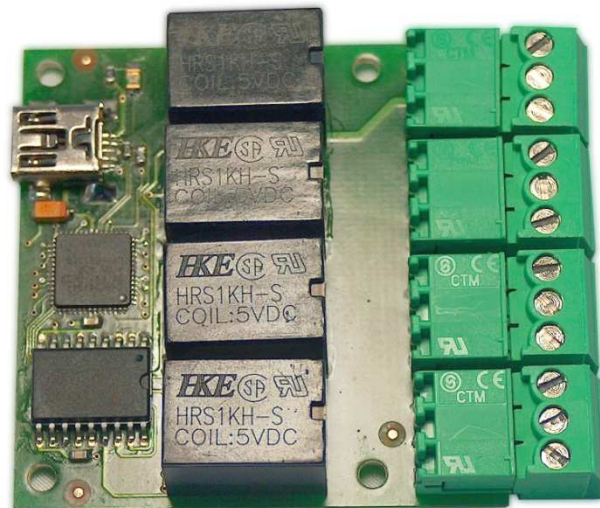

Revision history

Date	Doc. Rev.	Changes
21-Jun-2011	Rev. 1.4	Disclaimer Update
17-Jan-2011	Rev. 1.3	Modified Sample Rate Range
29-Oct-2010	Rev. 1.2	Added Operating Temperature Range
30-Sep-2010	Rev. 1.1	Added USB Vendor ID and Product ID
28-Feb-2008	Rev. 1.0	Initial Release
22-Oct-2007	Rev. 0.9	Preliminary Release



Contents

1. Introduction	3
1.1 Reference Documents	3
2. Hardware Specifications	4
2.1 Relay	4
2.2 Relay Output Circuit	4
2.3 Contact Characteristics	4
2.4 Pin Assignment	4
2.5 Supported Relay Features	5
2.6 USB Interface	5
2.7 Operating Temperature Range	5
3. Software Specifications	6
3.1 INTERRUPT OUT Report Contents (Real time data)	6
3.2 INTERRUPT IN Report Contents (Real time data)	7
3.3 FEATURE Report Commands	7
4. Technical Specifications	9
4.1 Current Consumption	9
4.2 Mechanical Dimensions	9
4.3 RoHS Compliance	9



1. Introduction

The Oak Relay is a USB attached relay output card with 4 independent channels. It is designed to be used for 24V applications but can also be used to switch any voltage up to 30V DC and 120V AC.

All channels are electrically isolated from each other as well as from the USB circuit. Every channel can be used as normally-open contact, normally-closed contact or as change-over contact. To simplify installation, each Oak Relay output channel has disconnectable interfaces. The mating connector features screw terminals to allow a quick attachment of bare wires.

The relays can be switched with a maximum USB latency of 1ms. The report rate for reading the state of the relays is user adjustable from 1ms to 65s.

The Oak Relay can be integrated in a custom application very easily. The operating power as well as real time relay switch instructions and uncritical device configuration data are all transferred through a simple USB cable. The low power consumption, including automatic entering into sleep mode, allows using the device not only in fixed installation, but also in mobile applications.

1.1 Reference Documents

Relay Datasheet

www.farnell.com/datasheets/70413.pdf

Programming Guide to the Oak Sensor Family



2. Hardware Specifications

2.1 Relay

The relay board consists of four Multicomp MCS1KHS relays. These are small relays with a fully sealed case. Due to the high coil sensitivity, the relays have low power consumption.

2.2 Relay Output Circuit

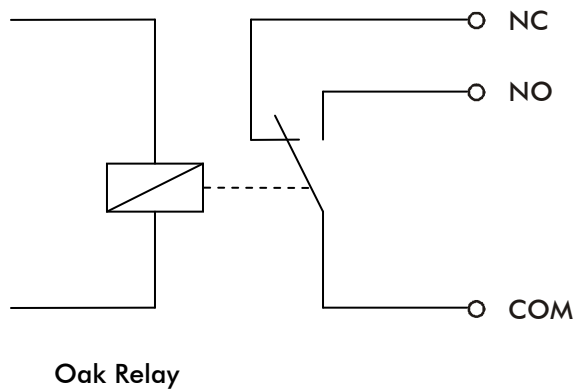

Figure 1: Relay output circuit for each channel

2.3 Contact Characteristics

Contact rating (resistive load)	1A at 24V DC 1A at 120V AC
Switching voltage	30V DC maximum 120V AC maximum
Contact Resistance	100mΩ maximum

2.4 Pin Assignment

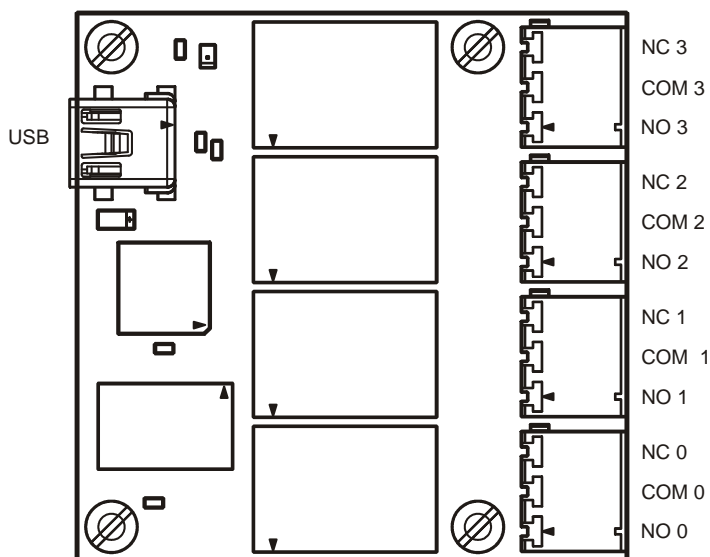

Figure 2: Pin assignment of the Oak Relay device



Oak Relay Datasheet

2.5 Supported Relay Features

Set, reset and toggle relay output

Read relay state

2.6 USB Interface

Interface: USB 2.0 Full Speed (12Mbits/s)

Connector: Standard USB Mini-B

Device Class: HID

Vendor ID: 0x1B67

Product ID: 0x000D

Update Rate: 4ms to 65s, user adjustable

Report Rate: 1ms to 65s, user adjustable

2.7 Operating Temperature Range

Minimum Operating Temperature: -10°C

Maximum Operating Temperature: +55°C



3. Software Specifications

All Oak Devices are implemented as HID devices. Thus driver support is built into all major operating systems.

The relay switching control is transmitted through an INTERRUPT OUT report, whereas the reading of the actual relay state is transmitted through an INTERRUPT IN report. Therefore, real time processing can be guaranteed. The data can be sent and received by the host using regular file write and read operation. Chapter 3.1 and 3.2 describes the contents of this report.

On an independent communication channel, device configuration is done using FEATURE reports that are 32 Bytes in length. Special operating system calls exist to transmit / receive feature reports. Chapter 3.3 shows the structure of a feature report for each supported command.

Please refer also to the document "Programming Guide to the Oak Sensor Family" for more details.

3.1 INTERRUPT OUT Report Contents (Real time data)

- 8 Bit Relay 0 Command
- 8 Bit Relay 1 Command
- 8 Bit Relay 2 Command
- 8 Bit Relay 3 Command

For changing the state of the relays, an interrupt out report has to be sent containing four 8bit values. Each value contains the command for one relay. The 8 bit values are divided into two 4bit nibbles. The lower nibble (bits 3 to 0) contains the relay command for normal operation mode, whereas the higher nibble (bits 7 to 4) contains the relay command for standby mode.

Bit#	7..4	3..0
Content	StandbyMode	NormalMode

The following table describes the significance of the StandbyMode and NormalMode values

Value	Function
0	Relay Off
1	Relay On
2	Relay Toggle
3-15	Hold Previous State

Attention: If the relays are configured to be switched on in the standby mode, the device is not longer USB compliant, because the relays consume more current than allowed in the standby mode.



3.2 INTERRUPT IN Report Contents (Real time data)

- 16 Bit Frame Number 10^{-3} s
- 8 Bit State Relay 0
- 8 Bit State Relay 1
- 8 Bit State Relay 2
- 8 Bit State Relay 3

The interrupt in report returns for the relay states a 0 if the according relay is switched off or a 1 if it is on.

3.3 FEATURE Report Commands

3.3.1 Report Mode

Byte#	0	1	2	3	4	5
Content	GnS	Tgt	0x01	0x00	0x00	RPTMODE

- GnS:
 - 0 = Set
 - 1 = Get
- Tgt
 - 0 = RAM
 - 1 = Flash
- RPTMODE:
 - 0 = After Updating
 - 1 = After Change
 - 2 = Fixed Rate (Factory Default)

3.3.2 LED Mode

Byte#	0	1	2	3	4	5
Content	GnS	Tgt	0x01	0x01	0x00	LEDMODE

- GnS:
 - 0 = Set
 - 1 = Get
- Tgt
 - 0 = RAM
 - 1 = Flash
- LEDMODE:
 - 0 = Off (Factory Default)
 - 1 = On
 - 2 = Blink Slowly
 - 3 = Blink Fast
 - 4 = Blink 4 pulses

3.3.3 Report Rate

Milliseconds between two IN reports. This parameter will only be regarded if Report Mode = 2 (fixed rate)

Byte#	0	1	2	3	4	5	6
Content	GnS	Tgt	0x02	0x00	0x00	RptRate LSB	RptRate MSB

- GnS:
 - 0 = Set
 - 1 = Get
- Tgt
 - 0 = RAM
 - 1 = Flash
- RptRate: Report Rate [ms]



Oak Relay Datasheet

3.3.4 Sample Rate

This is the actual sample rate the relay board is working on. The sample rate is the interval time for reading the relay state of the board. If Report Mode = 0 (After Updating) this is also the rate at which the device reports the state of the relays to the host PC.

Byte#	0	1	2	3	4	5	6
Content	GnS	Tgt	0x02	0x01	0x00	SampRate LSB	SampRate MSB

GnS: 0 = Set
 1 = Get

Tgt 0 = RAM
 1 = Flash

SampRate: Sample Rate [ms]

3.3.5 User Device Name

Byte#	0	1	2	3	4	5-25
Content	GnS	Tgt	0x15	0x00	0x00	UsrDevName

GnS: 0 = Set
 1 = Get

Tgt 0 = RAM
 1 = Flash

UsrDevName: User defined name for the whole device
 Null-terminated string, max. 20+1 characters

3.3.6 User Channel Name

Byte#	0	1	2	3	4	5-25
Content	GnS	Tgt	0x15	ChP1	0x00	UsrChName

GnS: 0 = Set
 1 = Get

Tgt 0 = RAM
 1 = Flash

ChP1 1 = Channel 0 (Frame Number)
 2 = Channel 1 (Relay 0)
 3 = Channel 2 (Relay 1)
 4 = Channel 3 (Relay 2)
 5 = Channel 4 (Relay 3)

UsrChName: User defined name for the channel
 Null-terminated string, max. 20+1 characters



4. Technical Specifications

4.1 Current Consumption

Symbol	Parameter	Conditions	Min	Typ	Max	Unit
I_a	Operating current	All relays on			190	mA
$I_{Stby}^{1)}$	Standby current	No USB activity			500	μ A

¹⁾ Only if relays are switched off in the standby mode. Otherwise, the device is not USB compliant.

4.2 Mechanical Dimensions

The PCB is designed to be mounted using four standard M2 screws. There are no components on the back side of the PCB, but there are through-hole components on top.

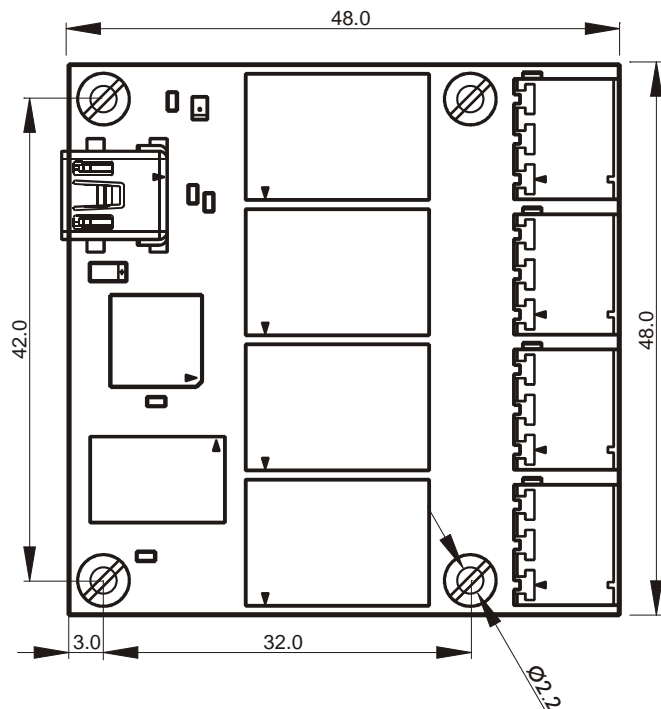

Figure 3: Mechanical dimensions of the Oak Relay device

4.3 RoHS Compliance

Unless otherwise stated, all Toradex products comply with the European Union's Directive 2002/95/EC: "Restrictions of Hazardous Substances".



Disclaimer:

Copyright © Toradex AG. All rights reserved. All data is for information purposes only and not guaranteed for legal purposes. Information has been carefully checked and is believed to be accurate; however, no responsibility is assumed for inaccuracies.

Brand and product names are trademarks or registered trademarks of their respective owners. Specifications are subject to change without notice.